

INSTALLATION INSTRUCTIONS

ATRO PARTS

ENGINEERED | DURABLE | RELIABLE
MANUFACTURED IN ST. CLAIR, MISSOURI | U.S.A.

PT50-59307 INSTALLATION TOOL

FOR USE WITH PIVOT BUSHINGS PB50-36914, PB50-36000, PB50-36000-EI, PB50-36001, PB50-36001-EI, PB50-36100, and PB50-36100-EI

Popular on Hendrickson Intraax/Vantraax Suspensions

NOTES:

- Lubricate ACME threaded bolt and thrust bearing with synthetic grease before each use
- Use of high torque drill is recommended over impact gun
- ACME bolt requires a 1 5/8" socket

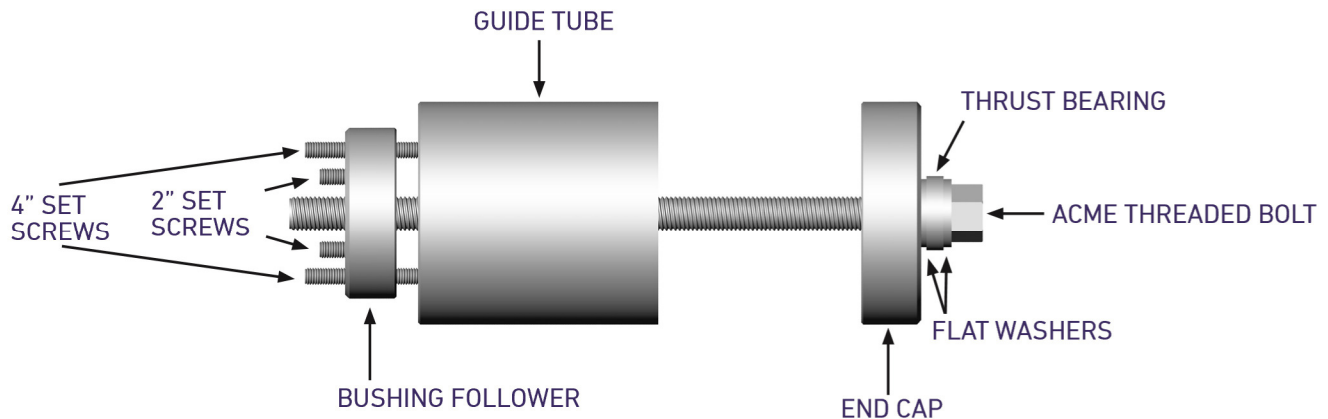

TOOL CONTAINS:

- (1) ACME Threaded Bolt
- (1) Thrust Bearing
- (2) Flat Washers
- (2) 4" Set Screws
- (2) 2" Set Screws
- (1) Guide Tube
- (1) Bushing Follower
- (1) End Cap

CELEBRATING 30 YEARS
ATRO
POLYURETHANE • SOLUTIONS

POLYURETHANE PARTS | SOLUTIONS FOR HEAVY TRUCKS

ATROBUSHING.COM
©2017 ATRO ENGINEERED SYSTEMS, INC.

6 Bolte Lane
St. Clair, Missouri 63077 | U.S.A.
(800) 325.6114 | Fax (866) 920.2005

DC00-10004

ATROBUSHING.COM | 1.800.325.6114

ATRO Engineered Systems, Inc. is not liable for any errors herein. All manufacturers' names and part numbers are used without permission; no endorsement, affiliation, or recommendation is implied. They are included for reference purposes only.